

FCC STATEMENT

This device complies with Part 15 of the FCC Rules. Operation is subject to the following two conditions:

- (1) This device may not cause harmful interference, and
- (2) This device must accept any interference received, including interference that may cause undesired operation.

Note:

This equipment has been tested and found to comply with the limits for Class B digital devices, pursuant to Part 15 of the FCC rules. These limits are designed to provide reasonable protection against harmful interference in a residential installation. This equipment generates, uses and can radiate radio frequency energy and, if not installed and used in accordance with the instructions, may cause harmful interference to radio communications. However, there is no guarantee that interference will not occur in a particular installation. If this equipment does cause harmful interference to radio or television reception, which can be determined by turning the equipment off and on, the user is encouraged to try to correct the interference by one or more of the following measures:

- Reorient or relocate the receiving antenna.
- Increase the separation between the equipment and receiver.
- Connect the equipment into an outlet on a circuit different from that to which the receiver is connected.
- Consult the dealer or an experienced radio/TV technician for help.

Use of shielded cable is required to comply with Class B limits in Subpart B of Part 15 of the FCC rules.

Do not make any changes or modifications to the equipment unless otherwise specified in the manual. If such changes or modifications should be made, you could be required to stop operation of the equipment.

Notice

If static electricity or electromagnetism causes data transfer to discontinue midway (fail), restart the application or disconnect and connect the communication cable (USB, etc.) again.

READ THIS FIRST

Trademark Information

- Microsoft® and Windows® are U.S. registered trademarks of Microsoft Corporation.
- Pentium® is a registered trademark of Intel Corporation.
- Macintosh is a trademark of Apple Computer, Inc.
- SD™ is a trademark.
- Other names and products may be trademarks or registered trademarks of their respective owners.

Product Information

- Product design and specifications are subject to change without notice. This includes primary product specifications, software, software drivers, and user's manual. This User Manual is a general reference guide for the product.
- The product and accessories that come with your camera may be different from those described in this manual. This is due to the fact that different retailers often specify slightly different product inclusions and accessories to suit their market requirements, customer demographics, and geographical preferences. Products very often vary between retailers especially with accessories such as batteries, chargers, memory cards, cables, pouches, and language support. Occasionally a retailer will specify a unique product color, appearance, and internal memory capacity. Contact your dealer for precise product definition and included accessories.
- The illustrations in this manual are for the purpose of explanation and may differ from the actual design of your camera.
- The manufacturer assumes no liability for any errors or discrepancies in this user manual.

SAFETY INSTRUCTIONS

Read and understand all **Warnings** and **Cautions** before using this product.

Warnings

If foreign objects or water have entered the camera, turn the power off and remove the batteries.



Continued use might cause fire or electric shock. Consult the store of purchase.

If the camera has fallen or its case has been damaged, turn the power off and remove the batteries.



Continued use might cause fire or electric shock. Consult the store of purchase.

Do not disassemble, change or repair the camera.



This might cause fire or electric shock. For repair or internal inspection, ask the store of purchase.

Do not use the camera in areas near water.



This might cause fire or electric shock. Take special care during rain, snow, on the beach, or near the shore.

Do not place the camera on inclined or unstable surfaces.



This might cause the camera to fall or tilt over, causing damage.

Keep the batteries out of the reach of children.



Swallowing the batteries might cause poisoning. If the batteries are accidentally swallowed, immediately consult a physician.

Do not use the camera while you are walking, driving or riding a motorcycle.



This might cause you to fall over or result in traffic accident.

Cautions

Load the batteries paying careful attention to the polarity (+ or –) of the terminals.

Loading the batteries with their polarities inverted might cause fire and injury, or damage to the surrounding areas due to the battery rupturing or leaking.



Do not fire the flash close to anyone's eyes.

This might cause damage to the person's eyesight.



Do not subject the LCD monitor to impact.

This might damage the glass on the screen or cause the internal fluid to leak. If the internal fluid enters your eyes or comes into contact with your body or clothes, rinse with fresh water. If the internal fluid has entered your eyes, consult a physician to receive treatment.



A camera is a precision instrument. Do not drop it, strike it or use excessive force when handling the camera.

This might cause damage to the camera.



Do not use the camera in humid, steamy, smoky, or dusty places.

This might cause fire or electric shock.



Do not remove the batteries immediately after a long period of continuous use.

The batteries become hot during use. Touching a hot battery might cause burns.



Do not wrap the camera or place it in cloth or blankets.

This might cause heat to build up and deform the case, resulting in fire. Use the camera in a well-ventilated place.



Do not leave the camera in places where the temperature may rise significantly, such as inside a car.

This might adversely affect the case or the parts inside, resulting in fire.



Before you move the camera, disconnect cords and cables.

Failure to do this might damage cords and cables, resulting in fire and electric shock.



Notes on Battery Usage

When you use the batteries, carefully read and strictly observe the **Safety Instructions** and the notes described below:

- Use only the specified batteries (Alkaline or Ni-MH rechargeable batteries).
- Avoid extremely cold environments as low temperatures can shorten the battery life and reduce camera performance.
- When you are using new rechargeable batteries or rechargeable batteries that have not been used for an extended period of time (the batteries that passed the expiry date are exception), it may affect the number of images that can be captured. Therefore, to maximize their performance and lifetime, we recommend that you fully charge the batteries and discharge them for at least one complete cycle before use.
- The batteries may feel warm after a long period of continuous use of the camera or the flash. This is normal and not a malfunction.
- The camera may feel warm after a long period of continuous use. This is normal and not a malfunction.
- If the batteries are not to be used for a long period of time, remove them from the camera to prevent leakage or corrosion and store them after no battery power is left. Stored for a long time in a fully charged condition, their performance may be impaired.
- Always keep the battery terminals clean.
- There is a risk of explosion if the batteries are replaced by an incorrect type.
- Dispose of used batteries according to the recycle instructions.
- We recommend charging the rechargeable batteries for 8 hours before the camera's first use.
- Never use batteries of different types (together) or mix old and new batteries.
- Never use manganese batteries.

CONTENTS

7 INTRODUCTION

- 7 Overview
- 7 Package Contents

8 GETTING TO KNOW YOUR CAMERA

- 8 Front View
- 9 Rear View
- 10 LCD Monitor Display

12 GETTING STARTED

- 12 Preparation
- 13 Turning the Power On/Off
- 13 LED Indicators
- 14 Choosing the Language
- 14 Formatting the Memory Card or Internal Memory

15 CAPTURE MODE

- 15 Capturing Images
- 15 Using the Zoom Function
- 16 Setting Focus
- 17 Setting the Scene Mode
- 18 Adjusting the Exposure (EV Compensation)

19 VIDEO MODE

- 19 Recording Video Clips
- 20 Playing Back Video Clips

21 PLAYBACK MODE

- 21 Playing Back Still Images
- 22 Thumbnail Display
- 22 Slideshow Display
- 23 Protecting Images
- 24 Erasing Images

25 MENU OPTIONS

- 25 Capture Menu
- 27 Video Menu
- 28 Playback Menu
- 29 Setup Menu

31 TRANSFERRING FILES TO YOUR COMPUTER

- 31 Downloading Your Files

32 SPECIFICATIONS

33 EDITING SOFTWARE INSTALLATION

34 USING THE CAMERA AS A PC CAMERA

- 34 Installing the PC camera driver

35 APPENDIX

- 35 Possible Number of Shots
- 36 Troubleshooting
- 37 Connecting to a PictBridge Compliant Printer

INTRODUCTION

Overview

Congratulations on your purchase of the new digital camera.

Capturing high-quality digital images is fast and easy with this state-of-the-art smart camera. Equipped with a 5.0-megapixel sensor, this camera is capable of capturing images with a resolution of up to 2560 x 1920 pixels.

Package Contents

Carefully unpack your camera and ensure that you have the following items:

Common Product Components:

- Digital Camera
- User's manual
- Software CD-ROM
- USB cable
- Camera strap
- Camera pouch
- 2 x AAA size batteries

Common (Optional) Accessories:

- SD/SDHC memory card



-
- Accessories and components may vary by retailer.

GETTING TO KNOW YOUR CAMERA

Front View

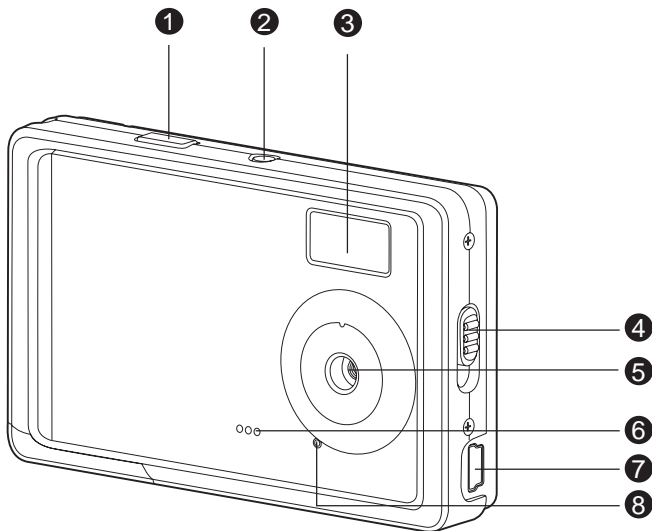

1. Shutter button

2. Power button

3. Flash

4. Focus switch

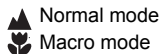

5. Lens

6. Beeper

7. USB connector

8. Self-timer LED

Rear View

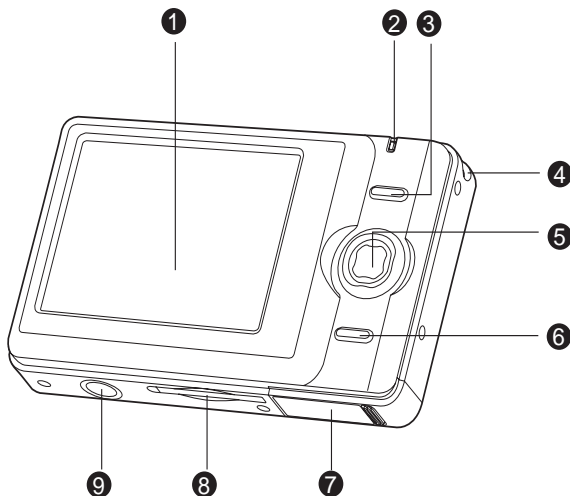

1. LCD monitor

2. Status LED

3. **OK** OK button

Q Digital Zoom button

4. Strap holder

5. 4-way control button

▲ Up button

MENU Menu button

▶ Right button

⚡ Flash button

▼ Down button

MODE Mode button

◀ Left button

⌚ Self-timer button



















6.  Playback button

7. Battery cover









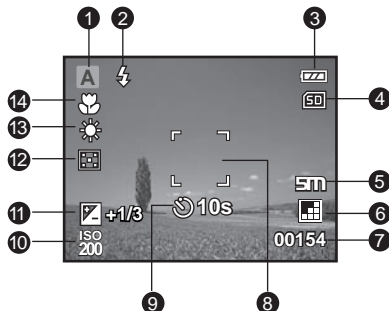

8. SD/SDHC memory card slot

9. Tripod socket

LCD Monitor Display

1. Mode indication
 - [**A**] Auto Mode
 - [] Sport Mode
 - [] Night Mode
 - [] Portrait Mode
 - [] Landscape Mode
 - [] Backlight Mode
2. Flash mode
 - [] Auto Flash
 - [] Forced Flash
 - [] Flash Off
3. Battery condition
 - [] Full battery power
 - [] Medium battery power
 - [] Low battery power
 - [] No battery power
4. Storage media
 - [] Internal memory (no card)
 - [] SD/SDHC memory card
5. Image size resolution
 - [**10M**] 3648 x 2736 (FW interpolation)
 - [**8M**] 3264 x 2448 (FW interpolation)
 - [**5M**] 2560 x 1920
 - [**3M**] 2048 x 1536
 - [**1.3M**] 1280 x 960
 - [**VGA**] 640 x 480
6. Image quality
 - [] Fine
 - [] Standard
 - [] Economy
7. Available number of shots
8. Main focus area
9. Self-timer icon
 - [] 10 sec.
 - [] 2 sec.



10. ISO
 - [] Auto
 - [] 100
 - [] 200
11. [] Exposure compensation
12. Metering
 - [] Average
 - [] Spot
13. W. Balance
 - [**Blank**] Auto
 - [] Daylight
 - [] Cloudy
 - [] Tungsten
 - [] Fluorescent
14. Focus setting
 - [**Blank**] Normal
 - [] Macro

Video mode [📹]

1. Mode icon
2. Available recording time
3. Main focus area
4. Battery condition
5. Storage media
6. Video resolution
7. Exposure compensation
8. W. Balance
9. Focus setting

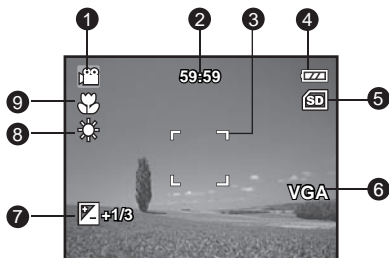

Playback mode [📷] - Still image playback

1. Play mode
2. Battery condition
3. Storage media
4. File number
5. Folder number
6. Protect icon

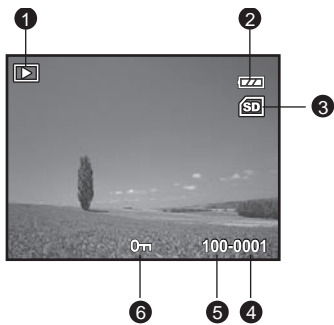

Playback mode [📹] - Video playback

1. Play mode
2. Mode icon
3. Total recorded time
4. Battery condition
5. Storage media
6. Video resolution
7. File number
8. Folder number
9. Playback indicator

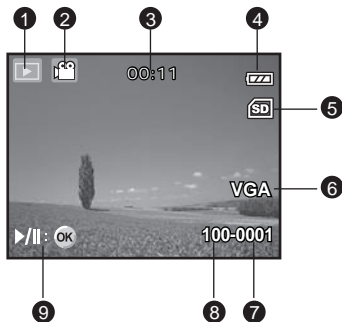

GETTING STARTED

Preparation

1. Attach the camera strap.
2. Open the battery cover.
3. Load the batteries with correct orientation as shown.
4. Close the battery cover and make sure it is locked securely.
5. Insert an SD/SDHC memory card (Optional).
 - The camera has 16MB internal memory (13.5MB available for image storage), but you can load an SD/SDHC memory card (SDHC memory card up to 4GB) to expand the camera's memory capacity.
 - Be sure to format the memory card with this camera before its initial usage.

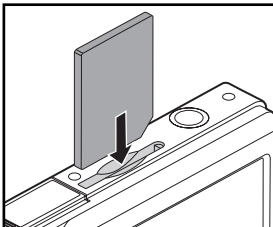
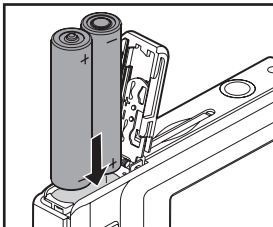
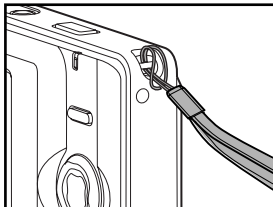

- To prevent valuable data from being accidentally erased from an SD/SDHC memory card, you can slide the write protect tab (on the side of the SD/SDHC memory card) to "LOCK".
- To save, edit, or erase data on an SD/SDHC memory card, you must unlock the card.
- To prevent damaging of an SD/SDHC memory card, be sure to turn off the power when inserting or removing the SD/SDHC memory card. If inserting or removing the SD/SDHC memory card with the power on, the camera will automatically turn off.
- Be careful not to drop the batteries when opening or closing the battery cover.

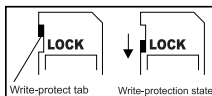

Turning the Power On/Off

Load the batteries and insert an SD/SDHC memory card before starting.

- Press the **POWER** button until the digital still camera turns on.
- To turn the power off, press the **POWER** button again.

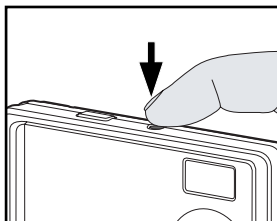

- The power is turned off automatically when the camera has not been operated for a fixed period of time. To resume the operation condition, turn the power on again. Refer to section in this manual titled "Auto Off" in the Setup Menu for further details.

LED Indicators

Indicators	State	Description/Activity
LED indicator	Solid green	The digital camera is powering up.
LED indicator	Solid green	The digital camera is ready to record images (or movies).
LED indicator	Blinking green	Reading/Writing files.
LED indicator	Blinking green	Charging the flash.
Self-timer indicator	Blinking red	The self-timer function is activated.

Choosing the Language

Specify in which language menus and messages are to be displayed on the LCD monitor.

1. Press the **MENU** button.
2. Select [Setup] menu with the **▶** button.
3. Select [Language] with the **▲ / ▼** buttons, and press the **OK** button.
 - The Language setting screen will be displayed.
4. Select the displayed language with the **▲ / ▼** buttons, and press the **OK** button.
 - The setting will be stored.

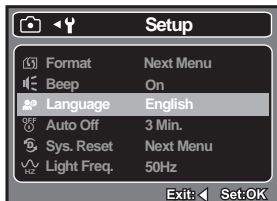

Formatting the Memory Card or Internal Memory

This utility formats the internal memory (or memory card) and erases all stored images and data.

1. Press the **MENU** button
2. Select [Setup] menu with the **▶** button.
3. Select [Format] with the **▲ / ▼** buttons, and press the **OK** button.
4. Select [Execute] with the **▲ / ▼** buttons, and press the **OK** button.
 - To cancel formatting, select [Cancel] and press the **OK** button.

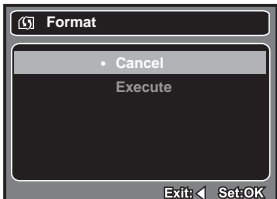
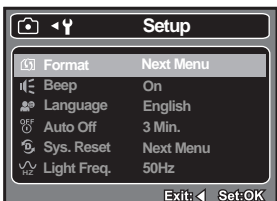

CAPTURE MODE

Capturing Images

Your camera is equipped with a 2.48" full color LTPS-TFT LCD monitor to help you compose images, playback recorded images/video clips or adjust menu settings.

1. Press the **Power** button to turn the power on.
2. Compose the image on the monitor screen so that the main subject is within the focus frame.
3. Press the shutter button to capture the image.

Using the Zoom Function

This camera is equipped with 4x digital zoom. You can enlarge the subjects by pressing the **OK / Q** button. A useful feature as it is, however, the more the image is magnified, the grainier the image may become.

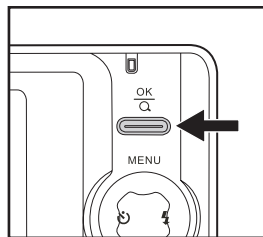

To capture a zoomed image, perform the following steps:

1. Press the **Power** button to turn the power on.
2. To activate the digital zoom, press the **OK / Q** button.
 - The status of digital magnification is displayed on the LCD monitor.
3. Compose your scene and press the shutter button to capture the image.



- The digital magnification ranges from 1.0x to 4.0x.
- As you record video clips, the zoom function cannot be activated.



Setting Focus

Images can be captured by sliding the focus switch to set the focus modes: [] macro or [] normal mode.

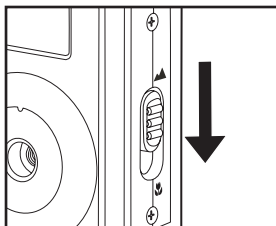
1. Press the **Power** button to turn the power on.
2. Slide the focus switch to your desired focus mode.
3. Compose your scene and press the shutter button.









The table below will help you choose the appropriate focus mode:

Focus mode	Description
 Normal	This mode is suitable for scenery and portrait shooting.
 Macro	Select macro to capture close-up images. When the lens is zoomed to its widest position you may focus objects as close as 60 cm.

Setting the Scene Mode

You can select the scene mode according to the shooting scene. There are 6 available modes in this scene mode.

- [] Auto: Select this mode to adjust point-and-shoot action.
- [] Sport: Select this mode when you want to photograph fast-moving subjects.
- [] Night: Select this mode when you want to capture dark scenes such as night views.
- [] Portrait: Select this mode when you want to capture an image that makes the person stand out against a defocused (blurred) background.
- [] Landscape: Select this mode to capture an image with infinity focus, hard sharpness and high saturation.
- [] Backlight: Select this mode when you want to capture images as the light comes from behind the object.

1. Press the **MENU** button.
 - The [Capture] menu is displayed.
2. Select [Scene Mode] with the **▲ / ▼** buttons, then press the **OK** button.
3. Select the desired scene mode with the **▲ / ▼** buttons, then press the **OK** button.
4. To exit from the menu, press the **◀** button.

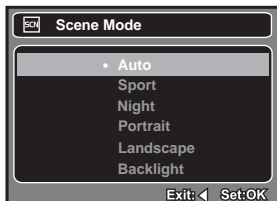
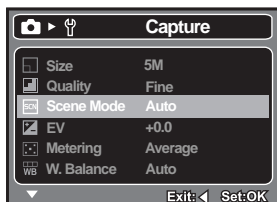

Adjusting the Exposure (EV Compensation)

You can manually adjust the exposure determined by the digital camera. Use this mode when the proper exposure cannot be obtained, for example, when the contrast (difference between light and dark) between the subject and the background is extremely large. The EV compensation value can be set in the range from -2.0EV to +2.0EV.

1. Press the **MENU** button.
 - The [Capture] or [Video] menu is displayed.
2. Select [EV] with the ▲ / ▼ buttons, then press the **OK** button.
3. Use ▲ or ▼ to set the range of EV compensation value from -2.0EV to +2.0EV, then press the **OK** button.
4. To exit from the menu, press the ◀ button.

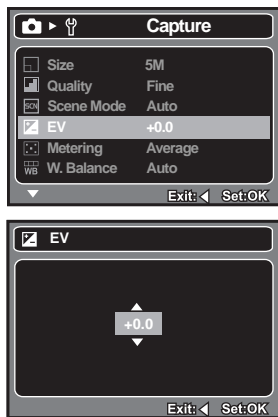

Ex.: In Camera Mode

Effective Subjects and Set Values

+(positive) compensation	-(negative) compensation	Backlight correction (+1/3 EV, fixed)
<ul style="list-style-type: none">* Printed matter with black text on whitish paper.* Backlighting.* Bright scenes or strong reflected light such as ski slopes.* When the sky accounts for a large area on the screen.	<ul style="list-style-type: none">* People illuminated by a spotlight, in particular, against dark background.* Printed matter with white text on blackish paper.* Weak reflecting bodies such as evergreen trees or darkish leaves	<ul style="list-style-type: none">* When the background is bright and the subject is dark.* When subjects (people) have a light source such as the sun to their backs.

VIDEO MODE

Recording Video Clips

This mode allows you to record video clips at a resolution of VGA (640 x 480) / QVGA (320 x 240) pixels.

1. Press the **MODE** button to set the camera mode to [].
2. Compose the image.
3. Press the shutter button.
 - The recording of the video clip will start.
 - Pressing the shutter button one more time will end the recording of the video clip.
 - The recording time depends on the storage size and the subject of the image to be recorded.

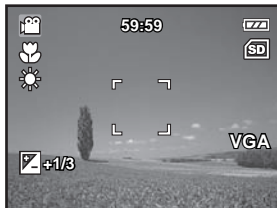

-
- When recording a video clip, the flash cannot be used.
 - If the write speed of your SD/SDHC memory card is not fast enough for recording video clips in the currently selected size, the video recording will stop. In this case, select a video size lower than the current one.

Playing Back Video Clips

You can play back recorded video clips on the camera.

1. Press the [] button.
 - The last image appears on the screen.
2. Select the desired video clip with the ◀ / ▶ buttons.
3. Press the **OK** button.
 - A press of the ▶ / ◀ buttons during playback allows fast forward play / fast reverse play.
 - To stop video playback, press the ▼ button.
This stops playback and returns to the start of the video clip.
 - To pause video playback, press the **OK** button.
This pauses video playback.
To cancel pause, press the **OK** button again.





-
- Video clips cannot be displayed rotated or enlarged.
 - This camera does not have a built-in speaker so that you can not play back sound with the camera. To play the video clip back on your computer, you may use either Windows Media Player or Apple "Quick Time Player".
 - Quick Time basic player is available free of charge, compatible with Mac and Windows-computers and can be downloaded from the Apple web site at www.apple.com. For help using Quick Time Player usage, please refer to the Quick Time on-line help for more information.

PLAYBACK MODE

Playing Back Still Images

You can play back the still images on the LCD monitor.

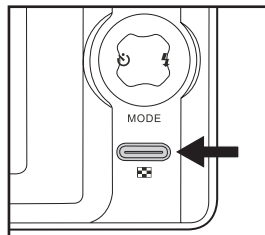

1. Press the [] button.
 - The last image appears on the screen.
2. The images can be displayed in reverse or forward sequence with the ◀ / ▶ buttons.
 - To view the previous image, press the ◀ button.
 - To view the next image, press the ▶ button.
3. Press the **OK** /  button to adjust the zoom ratio. The magnification factor is displayed on the LCD monitor.
4. To view different portions of the images, press the ▲ / ▼ / ◀ / ▶ button to adjust the display area.



- An [] icon is displayed with the video data.
- The magnification factors range from 1x to 4x (within 4 stages: 1.0x, 2.0x, 3.0x, and 4.0x).

Thumbnail Display

This function allows you to view 9 thumbnail images on the LCD monitor simultaneously so you may search for a particular image.

1. Press the [] button.
 - The last recorded image appears on the LCD monitor.
2. Press the **MENU** button.
 - The playback menu is displayed.
3. Select [Thumbnail] with the \blacktriangle / \blacktriangledown buttons, then press the **OK** button.
 - Nine thumbnail images are displayed simultaneously.
 - For recorded video clips, the [] video mode icon will be displayed.
4. Use the \blacktriangle / \blacktriangledown / \blacktriangleleft / \blacktriangleright button to move the cursor to select the image to be displayed at regular size.
5. Press the **OK** button to display the selected image on full screen.



Slideshow Display

The slideshow function enables you to playback your still images automatically in order one image at a time.

1. Press the [] button..
2. Press the **MENU** button.
 - The playback menu is displayed.
3. Select [Slide Show] with the \blacktriangle / \blacktriangledown buttons, then press the **OK** button.
4. Select the desired interval time with the \blacktriangle / \blacktriangledown buttons, and press the **OK** button.
 - The slideshow starts.
5. To stop the slide show during playback, press the **OK** button.
 - The image is displayed on screen when you press the **OK** button.

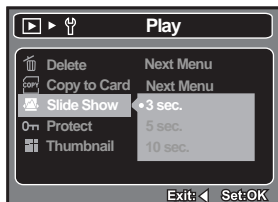

- The Auto Off function does not operate during slide show.
- All still images in the folder are automatically played back.
- Video files are displayed first frame image, and they are not played back.

Protecting Images

Set the data to read-only to prevent images from being erased by mistake.

1. Press the [] button.
2. Select the image that you want to protect with the ◀ / ▶ buttons.
3. Press the **MENU** button.
4. Select [Protect] with the ▲ / ▼ buttons, and press the **OK** button.
5. Select [Single], [All], or [Select] with the ▲ / ▼ buttons, and press the **OK** button.
 - [Single]: Protects the selected image or the last image.
 - [All]: Protects all of the images.
 - [Select]: Select the image you want to protect in thumbnail mode.
6. Select [Lock] with the ▲ / ▼ buttons, and press the **OK** button.
 - Protection is applied to the image and the camera returns to the previous menu mode.
 - The protect icon [🔒] is displayed with protected images.
 - When [All] has been selected, [🔒] is displayed with all the images.

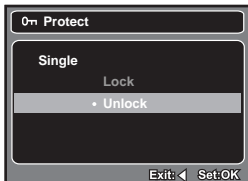
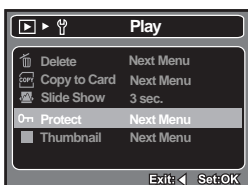

Canceling the Protection

To cancel protection for only one image, display the image on which you want to remove the image protection.

1. Select [Protect] with the ▲ / ▼ buttons from the playback menu, and press the **OK** button.
2. Select [Single], [All], or [Select] with the ▲ / ▼ buttons, and press the **OK** button.
3. Select [Unlock] with the ▲ / ▼ buttons, and press the **OK** button.
 - The removal of image protection is executed and the camera returns to the previous menu mode.



- Formatting an SD/SDHC memory card or internal memory overrides protection, and erases all images regardless of their protected status.

Erasing Images

Erasing single image / Erasing all images

1. Press the [] button.
 - The last image will be displayed on the screen.
2. Select the image you want to erase with the ◀ / ▶ buttons.
3. Press the **MENU** button.
4. Select [Delete] with the ▲ / ▼ buttons and press the **OK** button.
5. Select [Single], [All], or [Select] with the ▲ / ▼ buttons, and press the **OK** button.
 - [Single]: Erases the selected image or the last image.
 - [All]: Erases all of the images except for the protected images.
 - [Select]: Select the image you want to erase in thumbnail mode.
6. Select [Execute] with the ▲ / ▼ buttons, and press the **OK** button.
 - To not erase, select [Cancel], and press the **OK** button.

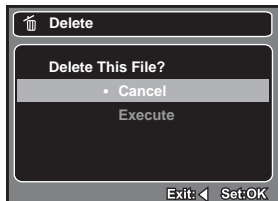
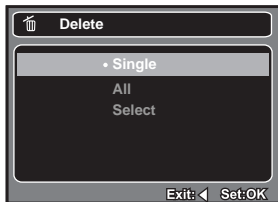
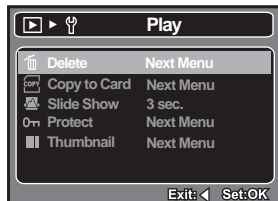

- Deleting an image will not affect sequential image numbering. For example, if you delete image number 240, the next captured image will be numbered 241 even though 240 no longer exists. In other words, an image-number is removed when an image is deleted and will not be reused or reassigned to another subsequently captured image.

MENU OPTIONS

Capture Menu

This menu is for the basic settings to be used when capturing still images.

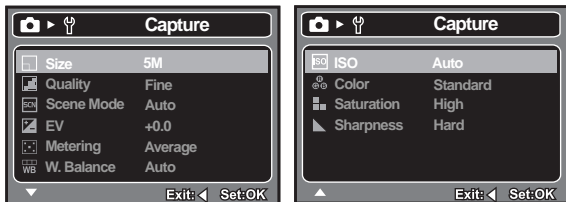

1. Press the **MODE** button to set the camera mode to Camera.
2. Press the **MENU** button.
3. Select the desired option item with the **▲ / ▼** buttons, and press the **OK** button to enter its respective menu.
4. Select the desired setting with the **▲ / ▼** buttons, and press the **OK** button.
5. To exit from the menu, press the **<** button.

Size

This sets the size of the image that will be captured.

- * [**10M**] 10M (3648 x 2736 pixels) (FW interpolation)
- * [**8M**] 8M (3264 x 2448 pixels) (FW interpolation)
- * [**5M**] 5M (2560 x 1920 pixels)
- * [**3M**] 3M (2048 x 1536 pixels)
- * [**1.3M**] 1.3M (1280 x 960 pixels)
- * [**VGA**] VGA (640 x 480 pixels)

Quality

This sets the quality (compression) at which the image is captured.

- * [] Fine
- * [] Standard
- * [] Economy

Scene Mode

Refer to section in this manual titled “Setting the Scene Mode” for further details.

EV

Refer to section in this manual titled “Adjusting the Exposure (EV Compensation)” for further details.

Metering

This sets the metering method for calculating the exposure.

* [] Average: The entire area of the screen is measured, and the exposure is calculated.

* [] Spot: A very small portion of the center of the screen is measured, and the exposure is calculated.

W. Balance

This sets the white balance for a variety of lighting conditions and permits images to be captured that approach the conditions that are seen by the human eye.

* [Blank] Auto

* [] Daylight

* [] Cloudy

* [] Tungsten

* [] Fluorescent

ISO

This sets the sensitivity for capturing images. When the sensitivity is raised (and the ISO figure is increased), photography will become possible even in dark locations, but the more pixelated (grainier) the image will appear.

* Auto / 100 / 200

Color

This sets the color of the image that will be captured.

* Standard / Vivid / Sepia / B&W

Saturation

This sets the saturation of the image that will be captured.

* High / Normal / Low

Sharpness

This sets the sharpness of the image that will be captured.

* Hard / Normal / Soft

Video Menu

This menu is for the basic settings to be used when recording video clips.

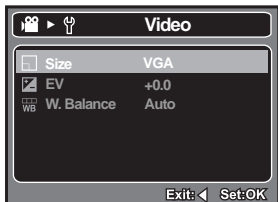

1. Press the **MODE** button to set the camera mode to [].
2. Press the **MENU** button.
3. Select the desired option item with the **▲** / **▼** buttons, and press the **OK** button to enter its respective menu.
4. Select the desired setting with the **▲** / **▼** buttons, and press the **OK** button.
5. To exit from the menu, press the **◀** button.

Size

This sets the size of the video clip that will be captured.

* [VGA] 640 x 480

* [QVGA] 320 x 240

EV

Refer to section in this manual titled “Adjusting the Exposure (EV Compensation)” for further details.

W. Balance

Refer to section in this manual titled “W. Balance” in Capture Menu for further details.

Playback Menu

In the [] mode, choose which settings are to be used for playback.

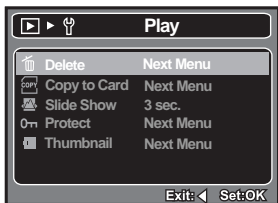

1. Press the [] button.
2. Press the **MENU** button.
3. Select the desired option item with the ▲ / ▼ buttons, and press the **OK** button to enter its respective menu.
4. Select the desired setting with the ▲ / ▼ buttons, and press the **OK** button.
5. To exit from the menu, press the ◀ button.

Delete

Refer to section in this manual titled “Erasing Images” for further details.

Copy to Card

Allows you to copy your files from the camera’s internal memory to an SD/SDHC memory card. Of course, you can only do this if you have a memory card installed and some files in internal memory.

* Cancel / Execute

Slide Show

Refer to section in this manual titled “Slideshow Display” for further details.

Protect

Refer to section in this manual titled “Protecting Images” for further details.

Thumbnail

Refer to section in this manual titled “Thumbnail Display” for further details.

Setup Menu

Set your camera's operating environment.

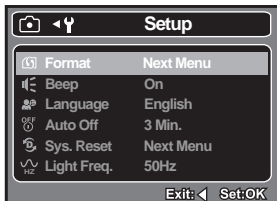

1. Press the **MENU** button.
2. Select the [Setup] menu with the ► button.
3. Select the desired option item with the ▲ / ▼ buttons, and press the **OK** button to enter its respective menu.
4. Select the desired setting with the ▲ / ▼ buttons, and press the **OK** button.
5. To exit from the menu, press the ◀ button.

Format

Refer to section in this manual titled “Formatting the Memory Card or Internal Memory” for further details.

Beep

This sets whether or not to mute the camera sound each time you press the camera's buttons.

* On / Off

Language

Refer to section in this manual titled “Choosing the Language” for further details.

Auto Off

If no operation is performed for a specific period of time, the power to the camera is automatically turned off. This feature is useful for reducing battery usage.

1 Min. / 3 Min. / 5 Min. /Off

Sys. Reset

This returns all basic settings to the camera's default settings.

* Cancel / Execute

Light Freq.

The function allows to change the light frequency of environment to 60Hz or 50Hz.

[60Hz]: the light frequency of environment is 60Hz

[50Hz]: the light frequency of environment is 50Hz

TRANSFERRING FILES TO YOUR COMPUTER

System Requirement

Windows	Macintosh
<ul style="list-style-type: none">■ Pentium 166 MHz or higher■ Windows 2000/XP/Vista■ 128MB RAM■ 128MB hard disk space■ CD-ROM drive■ Available USB port	<ul style="list-style-type: none">■ PowerPC G3/G4/G5■ OS 9.0 or later■ 128MB RAM■ 128MB hard disk space■ CD-ROM drive■ Available USB port

Downloading Your Files

1. Connect one end of the USB cable to an available USB port on your computer.
2. Connect the other end of the USB cable to the USB terminal on the camera.
3. Select [PC] using the ▲ / ▼ buttons, and press the **OK** button.
4. From the Windows desktop, double click on "My Computer".
5. Look for a new "removable disk" icon.
 - This "removable disk" is actually the memory (or memory card) in your camera. Typically, the camera will be assigned drive letter "e" or higher.
6. Double click on the removable disk and locate the DCIM folder.
7. Double click on the DCIM folder to open it to find more folders.
 - Your recorded images and video clips will be inside these folders.
8. Copy & Paste or Drag-N-Drop image and video files to a folder on your computer.

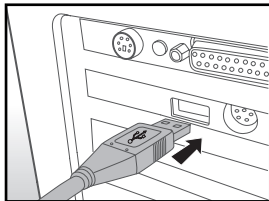

Mac users: Double-click the "untitled" or "unlabeled" disk drive icon on your desktop. iPhoto may automatically launch.



- Formatting the internal memory or SD/SDHC memory card by computer (via USB connection) as NTFS file system, the stored data will be automatically deleted by the camera.
- Do not format the internal memory or SD/SDHC memory card as NTFS file system.

SPECIFICATIONS

Item	Description
Image sensor	1/2.5" CMOS sensor
Effective pixels	5.0 Mega pixels
Image resolution	<Still image> 10M: 3648 x 2736 (FW interpolation), 8M: 3264 x 2448 (FW interpolation), 5M: 2560 x 1920, 3M: 2048 x 1536, 1.3M: 1280 x 960, VGA: 640 x 480 <Video clip> VGA: 640 x 480 (24 fps), QVGA: 320 x 240 (30 fps)
Recording media	16MB internal memory (13.5MB available for image storage) Supports SD/SDHC memory card (up to 4GB) (optional)
File format	Image format: JPEG; video format: Motion JPEG
Lens	F-no.: 3 Focus Length: 6.47 mm (equivalent to 39mm on a 35mm camera)
Focus range	Macro: 60 ~ 145 cm Normal: 145 ~ infinity
Shutter speed	1 - 1/1000 sec.
LCD monitor	2.48" full color LTPS-TFT LCD (153.6K pixels)
Self-timer	10 sec delay, 2 sec delay
Exposure compensation	-2.0EV~ +2.0EV (in 1/3EV increments)
White balance	Auto, Daylight, Cloudy, Tungsten, Fluorescent
ISO	Auto, 100, 200
Interface	USB connector
Power	2 x AAA size batteries (Alkaline or Ni-MH rechargeable batteries)
Dimensions	Approx. 90 x 55 x 18 mm (without protruding parts)
Weight	Approx. 82g (without batteries and memory card)

* Design and specifications are subject to change without notice.

EDITING SOFTWARE INSTALLATION

MediaOne Gallery SE - makes it the easiest way to manage and share your digital life with family & friends. The intuitive thumbnail library automatically organizes, updates and sorts files for the most natural way to browse your multimedia collection.

To install software:

1. Insert the CD-ROM that came with the camera into your CD-ROM drive.
The welcome screen appears.
2. Click the respective software name.
Follow the on-screen instructions to complete the installation.



-
- For more information about the operation of the software, refer to its respective help documentation.
 - For Windows 2000/XP/Vista users, please make sure to install and use the software in "Administrator" mode.
 - The software is not supported on the Mac.

USING THE CAMERA AS A PC CAMERA

Your camera can act as a PC camera, which allows you to videoconference with business associates, or have a real-time conversation with friends or family. To use the camera for videoconferencing, your computer system must include the items as below:

- Microphone
- Sound card
- Speakers or headphones
- Network or Internet connection

Installing the PC camera driver

The PC-camera driver included in the CD-ROM is exclusively for Windows. The PC camera function is not supported for Mac platforms.



















1. Insert the enclosed CD-ROM into your CD-ROM drive.
2. Follow the on-screen instructions to complete the installation.
3. After the driver installation is completed, restart your computer.

APPENDIX

Possible Number of Shots

■ Possible number of shots (still image)

The table shows the approximate shots that you can capture at each setting based on the capacity of the internal memory and the SD/SDHC memory card.

Size	Quality	Internal Memory	SD/SDHC memory card capacity						
			64MB	128MB	256MB	512MB	1GB	2GB	4GB SDHC
10m 3648 x 2736 (FW interpolation)	 Fine	3	21	43	88	178	333	667	1336
	 Standard	5	35	72	145	293	547	1097	2196
	 Economy	9	55	112	227	456	852	1707	3416
8m 3264 x 2448 (FW interpolation)	 Fine	3	23	48	98	198	370	741	1485
	 Standard	6	39	80	162	326	608	1219	2440
	 Economy	10	61	125	252	507	947	1897	3796
5m 2560 x 1920	 Fine	4	28	57	117	235	440	883	1767
	 Standard	8	46	95	193	388	724	1451	2904
	 Economy	13	73	149	301	604	1128	2258	4518
3m 2048 x 1536	 Fine	7	44	91	183	369	689	1380	2762
	 Standard	13	73	150	302	607	1133	2268	4539
	 Economy	21	115	234	471	945	1763	3529	7061
1.3m 1280 x 960	 Fine	21	115	234	472	946	1766	3535	7073
	 Standard	35	190	386	776	1556	2902	5808	11621
	 Economy	55	297	601	1207	2421	4515	9036	18078
VGA 640 x 480	 Fine	88	466	941	1891	3790	7068	14144	28297
	 Standard	145	766	1547	3107	6228	11612	23238	46489
	 Economy	226	1193	2407	4834	9689	18064	36148	72317

■ Possible recording time / sec (video clip)

Size	Internal Memory	SD/SDHC memory card capacity						
		64MB	128MB	256MB	512MB	1GB	2GB	4GB SDHC
VGA 640 x 480	00:14	01:04	02:12	04:27	08:58	18:00	36:05:00	01:01:12
QVGA 320 x 240	00:26	02:08	04:21	08:48	17:41	35:27:00	01:11:00	02:22:00

■ The above data shows the standard testing results. The actual capacity varies according to the shooting conditions and settings.

Troubleshooting

Refer to the symptoms and solutions listed below before sending the camera for repairs. If the problem persists, contact your local reseller or service center.

Symptom	Cause	Solutions / Corrective Actions
The power does not come on.	The batteries are not loaded.	Load the batteries correctly.
	The batteries are exhausted.	Replace with a new set of batteries.
		Please use only Alkaline or Ni-MH rechargeable batteries.
The batteries or camera feels warm.	Long period of continuous use of the camera or the flash.	
The start-up screen blinks after powering up.	The rechargeable batteries have reached the end of their effective life.	Replace with a new set of rechargeable batteries.
Even if I press the shutter button, the camera does not shoot.	The shutter button is not pressed all the way down.	Press the shutter button all the way down.
	The internal memory or memory card does not have any free capacity.	Insert a new memory card, or delete unwanted files.
	The flash is charging.	Wait until the status LED turns green.
	The memory card is write-protected.	Remove the write-protection.
The camera cannot focus.	The lens is dirty.	Wipe clean with a soft, dry cloth or lens paper.
	The distance to the subject is smaller than the effective range.	Get your subject within the effective focus range.
Files cannot be deleted.	The file is protected.	Cancel protection.
	The memory card is write-protected.	Remove the write-protection.
Cannot download images.	The free space on the hard disk in your computer may be insufficient.	Check whether the hard disk has a space for running Windows, and if the drive for loading image files has a capacity at least that of the memory card inserted in the camera.

Connecting to a PictBridge Compliant Printer

Read this section if the model you purchased is included with the PictBridge functions. If a printer that supports PictBridge is available, images can be printed by connecting the digital still camera directly to the PictBridge-compatible printer without using a computer.

Connecting the camera to the printer

1. Connect one end of the USB cable to your camera.
2. Connect the other end of the USB cable to the USB port on the printer.
3. Select [Printer] with the ▲ / ▼ buttons, and press the **OK** button.

Printing images

When the camera is properly connected to a PictBridge compliant printer and set to [Printer], the PictBridge menu is displayed on the monitor.

1. Select the item you want to configure with the ▲ / ▼ buttons, and press the **OK** button.
 - [Images]: Select whether you want to print specific image or all images. You may also select printing number for specific image.
 - [Size]: Select the desired paper size according to the printer type.
 - [Layout]: Select the desired printing layout according to the printer type.
 - [Print]: After all settings are configured, select this item to start printing.
2. If you select [Images] in the previous step, the figure shown on the right hand side will appear. Select [Select], [All] with the ▲ / ▼ buttons, and press the **OK** button.
 - [Select]: Select to print one specific image.
 - [All]: Select to print all images.

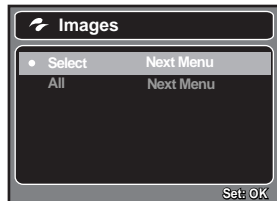
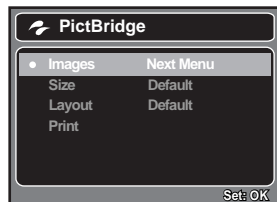
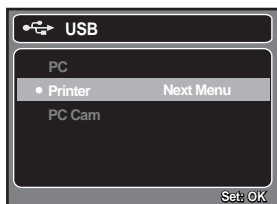

- If you select [Select] in the previous step, the figure shown on the right hand side will appear.
 - Select the image that you want to print with the ◀ / ▶ buttons.
 - Select the [Print Num] (up to 99) with the ▲ / ▼ buttons.
 - After selecting the desired image and printing number, press the **OK** button to confirm.

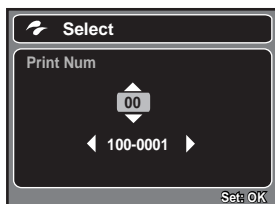

- Select [Print] with the ▲ / ▼ buttons, and press the **OK** button to start printing.

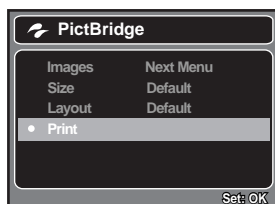

- The printing starts and the figure shown on the right hand side appears.
 - The [COMPLETE] will be displayed temporarily, reminding you that the printing procedure is finished.
 - If a print error is detected, the [PRINT ERROR] will be displayed.



- The image printing may be failed if the power to the camera is cut off.